

++++
NOTE: THE AUTHOR SHALL NOT BE HELD RESPONSIBLE IN ANY WAY
FOR THE USE OF THE INFORMATIONAL CONTENT OF THIS ARTICLE,
OR DAMAGES OR INJURIES ARISING FROM THE USE OF SAID CONTENT.
++++

BerndFritzLudwig@gmx.de

QUAD-405 Modification (and related stuff), version 6/2005 (two new and important modifications by Keith Snook included).

Previous versions on QUAD-WORLD and AUDIOCIRCUIT – the former seems to be dead now, the latter came back to life recently. Thanks to G. Hutchison for stylistic improvements! The new figures are from an earlier version posted on the AUDIO-Circuit-Website, <http://www.audiocircuit.com>, thanks!

Contents:

Intro

A) Input-stage

- 1) Operational-Amplifier (OpA)
- 2) Input-stage gain
- 3) Caps & resistors in general

B) Output-Stage

- 1) Drivers
- 2) Dumpers

C) Miscellaneous

D) Power-Supply

E) Summary

F) Appendices

- I) How does the 405-circuit basically work?
- II) The current-dumping-principle
- III) A note on slew-rate and bandwidth
- IV) The development of the 405
- V) Replacement-parts
- VI) Schematics

Intro

The 'QUAD 405' was in production from 1976 to 1993. About 160.000 copies were built. There were several minor changes in the circuitry during these nearly 20 years. At SN 59000 a major revision took place, and in 1981, at SN 65000, a refined protection-circuit gave opportunity to rename the amp to 'QUAD 405-2' (see Appendix IV below). This new protection-circuit aside, all modifications (even those in later versions of the 405-2) can be applied to the early models without great expenditure. I think at least some of these modifications are in fact worth applying to the older models, just to reveal all the qualities of the 405's basic conception. And there are some other easy -- and very cheap -- modifications that will improve performance further, including a simple modification of the protection-circuit which will overcome the main weakness of the original 405.

A note on nomenclature: In the following, "405-1" will refer to the original 405, "405-2" to the 405-2 (as you might have guessed!) and "405" to both of them.

All of the circuit-changes described below have been applied successfully to my own two 405-1 (SN. ~45.000, Circ. Diag. M12333, PCB 12368 iss.10) some years ago and most of them by others to theirs with similar results. Some of the mods (especially those in sect. B below) aim at better performance with low-impedance loads (the 405 was designed during the blessed '8-Ohm-days', but I wanted to drive speakers with impedance-drops down to less than 3 Ohms). The others aim at better overall performance. Many of these (in sect. C) are just an 'upgrade' from the earliest 405-1 to the latest 405-2 (so there often is no need to apply them), some are an 'anticipation' of the improved 306/520f/606-family circuitry [as indicated], and some are my own proposals (especially those in sect. A and B). Some useful simplifications of my original mods have been proposed by others. They are incorporated into this document even if I didn't apply them to my own amps afterwards ("never change a winning team"). I put my soldering-iron out of my hands some time ago....

The 405-schematics (see Appendix VI below) are not required for most of the modifications since component-labels are printed onto the PCB. However: to understand what you are doing, studying schematics is imperative (Appendix I should help). I will add some information about the circuit in passing to give an idea where further improvements might be possible -- and where they are definitely not. This information might help as well if you have a problem with your 405, but they are NOT intended to make the Quad-service superfluous (neither am I!). Nevertheless there is a hint below how to cure a familiar 405 problem: The hum at the output after about 10 years of use.

The 'current-dumping' [CD] principle itself is no object of the following modifications (it just seems to work perfectly in the 405 and in its followers -- see Appendix II below). But thanks to it, the amp is very (very!) stable and the output-stage is what many people call "class-C" (unbiased) and thus rather uncritical concerning modification and component-upgrade: As long as the (passive) 'CD-bridge' is balanced, particular properties of the output-stage components may vary in a considerably broad range without affecting performance. The main goal of the 405-design was: A state-of-the-art amp that is suitable for mass-production and whose properties will stay unchanged over a long period. Consequently all relevant properties of the amp are determined by design and by those specs of components only for which a sufficiently tight tolerance is guaranteed by the suppliers already (as for example the resistance of a resistor or the offset of an OpA, in contrast to transconductance or saturation-voltage of a transistor). So there is no internal adjustment (quiescent-current, DC-offset etc.) necessary in the 405 and it should keep its specs perfectly over the whole lifetime (as long as the electrolytic caps do their job, of course, see below ...).

Don't hesitate criticising the following lines -- they just sum up my thoughts and collect passages from my '405 internet correspondence' since ~1990 (many thanks to all correspondents!). Actually I'm not an audio-engineer. I'm just a hobbyist who enjoyed some training in physics decades ago and studied JAES, EWW, rec.audio.tech -- and the QUAD-schematics (405/520/606). If anyone knows something about the further 'evolution' of current-dumping (in 606-2, 707 and 909), please let me know. Maybe we can learn something from it which applies to the 405 as well! (But as far as I know there are mainly modifications concerning the power-supply -- a replacement of the original transformer by a cheaper(?) ring-core-type f. e. -- but I am not sure.)

A) INPUT-STAGE

(In sum: Replace OpA, improve rail-decoupling, and reduce gain)

The task of the input-stage-OpA is 1) to amplify the input-signal 15 times (+23dB, inverted), 2) to form a ~13Hz, 12dB/oct high-pass and 3) to adjust output-dc to zero (hence the OpA has definitively nothing to do with the current-dumping-principle: the OpA-circuitry is plain conventional). R10 and R9/R11 [405-1] or D8/D9 [405-2] are only part of the output-voltage limiter required exclusively for the veteran ESL57 speakers. R9 should be short-circuited if the limiter is not used, R10 is superfluous then and may be short-circuited as well (although this should not have any significant effect).

I think the first two (and sonically most significant) steps in upgrading the 405 are:

[1] To replace the veteran OP-Amps: LM301 and TL071 (or LF351) were hardly state of the audio-art in their time (the seventies) -- and nowadays they are definitely not. And

[2] To reduce noise of the input-stage. There are two ways now (2004) to achieve this.

1) OP-Amp

1a) Thanks to the plain, moderate-impedance-design (~10k) of that stage there is a wide choice of recent OP-amps that might fit (FET as well as Bipolar) for drop-in-replacement (usual 741-pin-layout). But there is no use in looking for an ultra low voltage-noise OpA (like LT1028 or AD795), since thermal noise (~15nV/Sqrt(Hz)) of the input-resistors (R2||R4||R6, ~10k in series(!) with the input) will be dominant anyway with any reasonable OpA. To my experience there is even no audible noise-difference between a NE5534A (~4nV/Sqrt(Hz)) and a TL071 (~20nV/Sqrt(Hz)). And since the OpA works as an inverter, common-mode-rejection (which seems to be a 'weaker' point with some OpAs) can be ignored as well. It is safe to bend away (or even cut off) pin 1 (or pin 8) if a new OpA is inserted (just to prevent any unexpected effect of the small 3p3-cap which was fitted between 1 and 8 in the early 405-1s to compensate the LM301 suitably). SN below 29000: Change D1/D2 from 12V to 15V Zeners.

I would strongly recommend Burr-Brown's neutral (call them 'transparent') "audio-workhorses" OPA604AP or OPA134 (FET, single, not: OPA2604 or OPA2134, double) or the popular NE5534 (Bipolar, single, not: NE5532, double – both still hard to beat in moderate-gain applications). To my experience all of them do an excellent job here and no further improvement is to be expected from more "esoteric" (and more expensive) components like OPA627, AD825 etc. On the contrary, especially the faster OPAs might cause stability-problems due to PBC-layout and hence deteriorate performance (concerning reasonable slew-rate-requirements see Appendix III below!).

1b) Two ~100nF-caps (here cheap ceramics are first choice!) from the OpA's power-supply pins (7 and 4) to ground (pin 3 in this case) are imperative. Otherwise most of the 'modern' Audio-OpAs will have a tendency to ringing or even to rf-oscillation (despite their better PSR-ratios!). Just dropping in a 5534 for example makes things definitively worse (ringing!—BTW: that kind of folly is an easy – and maybe the only! - way to "prove" that the 5534 is a "terribly-sounding" OpA). The caps should be

soldered onto the copper-side of the PCB directly under the OpA-case (since every fraction of an inch may count). An Alternative: Only one 100nF across the ps-pins, no cap to ground. People who prefer this version think that the two cap-version will inject PS-rubbish into the virtual earth (I leave it to you to find out whether this is significant or not).

1c) Since most modern Audio-OpAs need more quiescent-current (~6mA and sometimes even more) than the general-purpose veterans (~2mA), an improper power-off-behaviour might occur after OpA-replacement. The reason is, that ~+1.2V at the base of Tr2 (i. e. at the output of the OpA) is required for zero output (for details see Appendix I below). With the increased current requirements of the new OpAs, this is not granted up to the moment when the output-stage shuts down entirely at power-off (hence there is a noise).

It is very easy and straightforward to eliminate the power-off-problem for any new OpA by just adding a MPSA06 (or any other standard low-power NPN, >80V) as positive voltage-regulator (no need for a second one on the negative rail!):

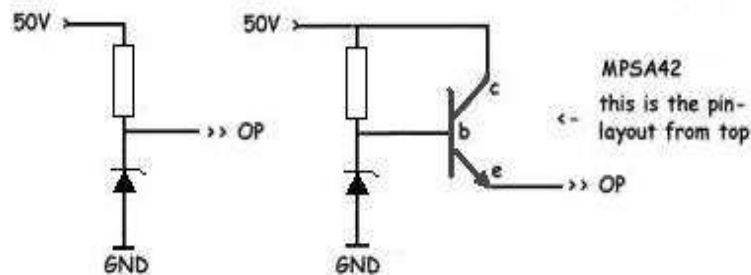

Now the 3k3-resistor/zener-combo (R7, D1) sets only the base-voltage, while the transistor delivers all the current to the OpA (hence the D1-current increases by about 2mA, which doesn't matter). It is possible as well, to reduce R7 appropriately for the OpA in question, but that will involve some trial and error and gives a less flexible solution nevertheless. To my experience the 'shut-down' is in fact absolutely noiseless with the simple regulator (there is only the original "infrasonic bump" left – which is inaudible and does no harm at all). -- The copper-track from the common D1/R7-soldering-pad to the OpA has to be cut through and the gap to be bridged by b-e of the transistor, then c has to be connected to the opposite end of R7 (that's it, no extra wires are required).

2) There are two versions of noise-reduction, one moderate and simple, and one more radical. The first was applied successfully to my two 405-1 during 1995. The second one was proposed by Keith Snook (on: <http://www.dc-daylight.ltd.uk/Valve-Audio-Interest/QUAD/QUAD-405-Modification/QUAD-405-Mods.html>) in 2004 and it is preferable by far. Since I put my soldering-iron out of hands by now, I didn't try it myself, but I am sure it will work perfectly. The first is still mentioned only for "historical" reasons – and because most information given still applies to the second.

2A) First version: The input-sensitivity of the 405 is much too high for most domestic applications (0.5V_{eff} for full output swing, just because Quad wanted to keep the 405 compatible to the 0.775V-standard). There is no use at all in attenuating a signal heavily by the volume-knob of the pre-amp just for driving a stage with too much gain afterwards. Reducing gain of the 405 input-stage by factor ~3 (for even more gain-

reduction help yourself!) to 1.5V for full output (that's just standard) will not only improve convenience with most pre-amps. At the same time it will reduce input-stage-noise, the effect of the preamp's noise-floor, and even the OpA's contribution to overall-distortion by 10dB. Of course, the relevance of the last point is debatable. But in any case: IF there is still any audible distortion generated by the OpA, gain-reduction will be a more efficient means to reduce it than for example any further improvement of the power-supply. Thanks to the modification SN-ratio will approach the (excellent) value of the 606. This improvement is extremely significant when efficient speakers are used.

You have to add three components directly onto the PCB (copper-side) to increase local feedback of the OpA (audio-range and above) as well as overall feedback (sub-audio-range, DC-control). All three new components are required since the sub-audio time-constants of the two feedback-paths -- and of the input path -- have to be preserved; otherwise the 12dB/oct.-slope of the input-high-pass will be corrupted. After the mod the stage will work at a gain of 4.6 (+13.5dB), that's where good, low-gain-stable Audio-OpAs are nearly unbeatable today. Don't use the LM301 -- or devices like the OP37 f. e. -- after the gain-reduction, they are not compensated for gain < 5 (the 5534 is just fine because it is stable for gain > 3 without further compensation).

Local feedback: Close to the OpA there is one MKT-capacitor C4 =47nF connected to R6=330k. Add [1] C4'=100nF (same type) across C4. Add [2] R6'=150k across R6=330k.

Overall feedback: Two 22k-resistors are connected to pin 2 (inverting input of the OpA): R3 which leads to the input cap C1=0.68uF and R4=22k which leads to C2=100uF. Add [3] R4'=10k across R4=22k (not across R3!).

That's it. You should use 1%-resistors for R6' at least (to keep the channel-balance). Tolerances of R4' and C4' are not too critical since the time-constants of the 13Hz-high-pass are subject to C2's much higher tolerance anyway (but 1%-resistors and 5%-caps are not really expensive ...). BTW: Moving your head or the speakers by a couple of inches will have more audible influence on frequency- and phase- response at any listening-position in any living-room than 10% or even 20% deviance of these components.

Two (or three) alternatives to step [3] (=overall feedback) exist. All these versions give the same frequency- (and thus phase-) response, but they are a little more difficult to apply (since you have to replace — not just to add — components), so take your choice (steps [1] and [2] are always the same as before)!

[3a] It is possible to reduce C2 from 100uF to 33uF instead of reducing R4 by shunting R4' (this makes sense especially when C2 is old and has to be replaced anyway). If a fitting non-polar type is available, take it; if a polar (tantalum) cap is used (like in older 405s): connect '-' to the ground, '+' to the OpA. (Maximum voltage of the caps doesn't matter here, 3V is already ample.)

If non-polar 33uF-caps are not available, two 'golden-ear' alternatives are at hand:

[3bi] Replace C2 by 2*68uF/25V in series (= ~34uF) with positive taps connected, and bias their junction to +15V by a ~270k-resistor from the negative OpA-supply.

This will eliminate any electrolytic/tantalum bias-problems (which were present in the original circuit). Correct biasing makes nearly every standard electrolytic/tantalum superior to any non-biased 'high-grade device'. -- Don't bother that it takes more than a minute then for the output-offset to drop from about +100mV to the target area < 2mV after power-on. This does no harm and is due to the huge time-constant for adjusting the C2/C2-junction to +15V: $\sim 200s = 270k \cdot 130u \cdot 2 \cdot \pi$ (I decided in favour of this value just to avoid even the slightest interaction of the rail-noise with the audio-signal -- see additional C2'=100n below as well).

[3bii] Since even polar 68uF/25V-caps (for [3bi]) are not very current, it might be more convenient to take 2*100uF/25V and to add R4'=43k across R4 to restore the proper amount of sub-audio-feedback (that's what I actually did). The same value for R4' is required if a non-polar 47uF is used instead of a non-polar 33uF [in 3a].

Further add C2'=100nF (propylene) across C2, even if you don't want to change the latter. This will compensate for rf-impedance of the electrolytic. I recommend inserting C2' into the former C2-position and to add the other caps [and the biasing-resistor] onto the copper-side.

2B) Second Version (design and diagram by Keith Snook 2004 - with a minor correction by myself concerning the value of C2):

Here the OpA-circuit (and with it the whole amp!) is changed from inverting to non-inverting function. At the same time, stage-gain is reduced.

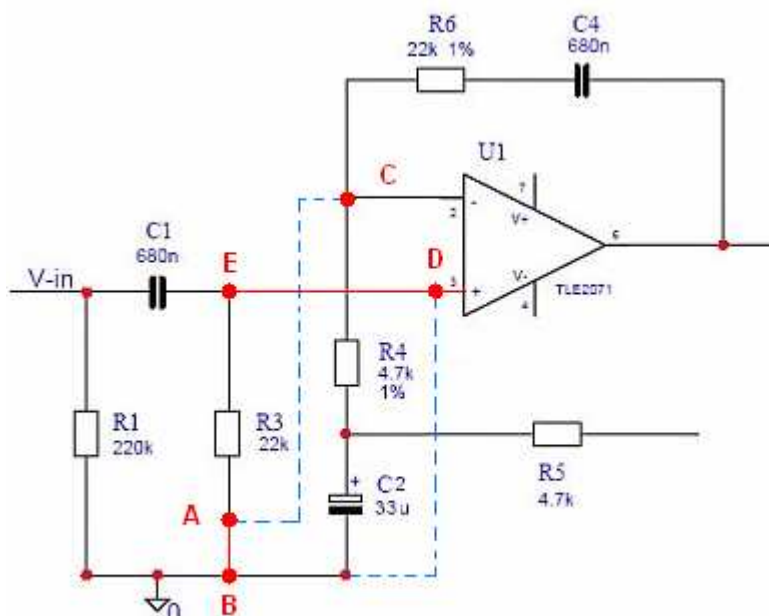

The input-cap is connected directly to the positive input (E-D) and the input-high-pass (C1,R3) is passive now (A-B). The former (blue) connections (A-C, D-B) are eliminated. Some components have to be changed as well:

- a) A $\sim 1.3V$ input-sensitivity version is shown above. Impedance- and gain-reduction were achieved by reduction of C4, C2, R4 and R6. 1uF across 33uF is fine.
- b) For the original 0.5V-sensitivity, R4 is 1k54 and C2 is 100uF (R6, C4 as shown).

Of course, even in this version C2 can be treated further by the “golden-ear-methods” of 3b from above.

Substantial noise-reduction is achieved with the 0.5V-version already, since the input “sees” only ~1k5 compared to 10k before. This will – OpA-noise ignored – give about 6 dB less noise. Of course, a $< 5\text{nV}/\sqrt{\text{Hz}}$ -OpA (like the 5534) is required to take advantage of this improvement. Since low-noise-OpAs have not been readily available at the time of the first 405-design, the non-inverting-version was not less noisy than the inverting then. But why the former was preferred by Walker/Albinson is not obvious to me – maybe it was just that they reproduced the topology from the 303 input-stage. Since frequency and phase-response are not changed, there should be no sonical difference between the two versions at all -- except for the lower noise.

The two input-stage-mods (OP-replacement and noise-reduction) together give a nice stimulation of the otherwise a bit lifeless (“behind-the-curtain-”) '405-sound'. The mods in C) and D) below are all less significant sonically.

3) A note on capacitors: Beside C2 only C1, C4 and C6 might influence the sound-quality directly. If C6 is a styro-type (as it is in the old 405-1 at least -- just to insure small tolerance), this is the best you can get, so don't touch! -- C1 and C4 are 'only' standard MKT-types -- but nevertheless no significant improvement by 'high-grade-devices' seems to be possible here: Due to the inverting OpA-circuit the 'distortions' generated by C1 and by C4 (if any) do cancel out each other at the summing-point as long as they are of same kind and order. -- Increasing C1 from .68uF to 1uF (which is praised as a “tweak” sometimes) is, of course, a harmless waste of time (always) and of money (depends on the new cap), but if you feel better with it, go ahead!

The electrolytics (C2 [tantalum, 6.3V], C5 [16V] and C10 [40V]) should be replaced after about 15 years (this applies to all audio-gear...) because they tend to dry out. Since electrolytics are the ONLY electronic components in a 405 that change their specs relevantly during human lifetime, the amp is in “mint-condition” again (at least sonically) after a replacement of these caps (as long as nothing else is really broken, of course).

For C2 see "2[3]" above.

Since C10 (the bootstrapper) is always adequately biased and the circuit-design is not sensitive to its specific properties – as C10 is inside the feedback-loop anyway. So it doesn't need any further consideration (bypassing it with smaller caps f. e. would be as pointless as painting it pink). On some later boards C10 is placed rather close to R31/31 which get very hot. So it would be better to mount the cap onto the backside of the PCB, this will increase its lifetime (thanks, Lars!).

100/120Hz-hum at the output is often caused by a faulty C5 -- so replace it even earlier when necessary (but if there is some mechanical noise from the transformer, there is no affordable cure — I'm afraid!). Since all electrolytics in the 405 are adequately biased (if you applied the above "golden-ear-mod", 3bii) there is nothing to complain about them. But if you distrust electrolytics in principle, adding 1uF (foil) across C5 might make sense (so even the last drop of rf-noise from the rails into the current-source -- if there is any left -- will be sucked up). Concerning C8 and C11: see section C) below.

4) Further there is no use in replacing any of the resistors by 1% metal-film or so-called audiophile parts. None of the resistor-tolerances is really critical. You might change most of the values by +-10% (often even +-20%) without changing

performance significantly. The only exceptions are those resistors that have been implemented 5% or 1% by the manufacturer anyway: Frequency-response at 20Hz and overall gain will change by $\sim\pm 1\text{dB}$, if you change the values next to the input by $\sim 10\%$. Gain will change with R16/20/21 and distortion will rise by about twice the percentage R38's deviates from the intended value. Even at the input metal-film resistors will not reduce noise audibly (I tried it, believe me and save your time!). If special 'audiophile' resistors could have any audible influence at all (I'll leave that point to the reader), it would be here indeed. But at least for R3 and R6 the same applies as for C1 and C4 above: if one of them does any damage to the sound, the other will compensate for it exactly, as long they are of the same type (no myth, merely math). In all other places the characteristics of the semiconductors f. e. have a by far bigger and much less predictable influence -- and have much higher tolerances.

B1) OUTPUT-STAGE, Drivers

(In sum: if your speakers are 8 Ohm, skip this whole section B)

The 'upper driver' (TR7) is part of the 'class-A-stage', and it might thus be tempting to try an upgrade from the venerable RCA 40872 ($\sim\text{BD244D}$, 5MHz) to a faster device (f. e. Motorola's 30Mhz-MJE15031, MJE15033, or Toshiba's 2SA1930). But there is absolutely no use in this kind of 'upgrade': At very low levels (and that is: everywhere outside the audio-range) the 'pre-drivers' (Tr3/4) alone determine the maximum-speed of the stage (via C11) -- and they are much faster than the driver itself. -- It would be a VERY bad idea to upgrade the 'lower driver' (Tr8) by a faster device since it is part of the dumpers, where high speed is rather unwanted (speed is even reduced intentionally by R37/L1/[C19] or R37/L4 [later]. A severe instability in a 405 with two SA1930 was reported to me -- probably the replacement was the cause. -- So everything is absolutely perfect with the 'cheap' and 'slow' drivers: Hands off!

B2) OUTPUT-STAGE, Dumpers

a) [405-1] Firstly there is a simple mod of the current-limiting circuit of the 405-1 which brings it a little closer to the 405-2's characteristics (and keeps the short-circuit-protection).

Step 1: Replace R27/29 (15k or 8k2) by a 36V-Zener-diode (1.3W -- pointing 'up' in the diagram -- not 'down' like D3-D6) with 2k7 (2W) in series. (It is more elegant, of course, to add the Zener and to replace R24 and R26 by 120R and 420R while leaving R27 at 15k, so the current through the network is not increased, and accordingly there is no need for 2W-resistors -- but this is a little more difficult to apply -- take your pick!). After this mod the current-limiter will still work as before at full output-swing and at short-circuit (just compare the voltage at the base of Tr5/6 at $V_{\text{out}} = 0\text{V}$ and at $V_{\text{out}} = 50\text{V}$ 'before' and 'after'), but it will allow full $\sim 7\text{A}$ with any load down to approx. 2 Ohm (output $> \sim 14\text{V}_{\text{peak}}$). This maximum of 7A/35V (across the device) is still inside the SOA of up-to-date transistors as long as the signal is periodic. Of course, it is not for continuous DC, but that should be no problem since then the clamp-circuit will cut in and reduce current to the "original" short-circuit-conditions. The original limiter dropped down continuously from 7A at $V_{\text{out}}=50\text{V}$ to 3.5A at short-circuit. See the following diagram which gives a rough picture. The power-limit into a given load is $I_{\text{max}} * V_{\text{out}}$ at that point where the load-line

crosses the limiter-characteristics (divide by 2 for P_{rms} , for example org. into 2 Ohm: $\sim 4 \cdot 8 / 2 = 16W$; mod_1 into 2 Ohm: $7 \cdot 14 / 2 = 50W$; org. and mod_1 into 4 Ohm: $7 \cdot 36 / 2 = 100W$).

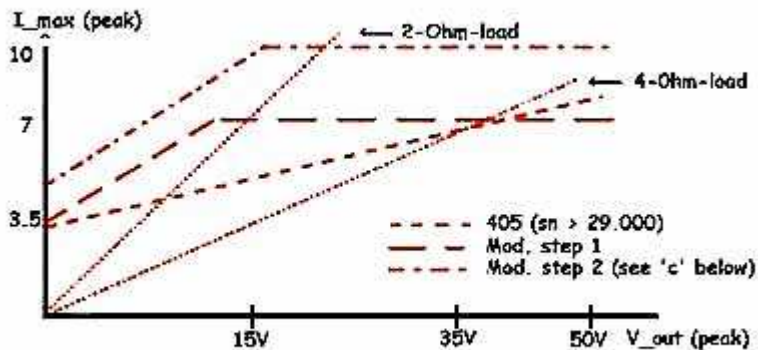

In any case, there probably will not be THD < 0.01% at all 'unprotected' levels after this mod, for sure, and not 50W _continuous_ sine-drive into 2 Ohm (so you have to take some care not to overheat the amp when driving low-impedance-loads with continuous signals on the workbench!) -- but there will be no interference by the protection-circuit during for example 7A-peaks into 2 Ohm (~50W).

Further: 330nF (or 680nF) connected from base to emitter of TR5 and TR6 should eliminate any problems (if there are -- as some people suppose) of the protection-circuit due to short pulses caused by signal peaks into highly inductive or capacitive loads -- or even D3 and D4's 'switching' on and off. Maybe you want to add them to be on the safe side.

b) The following modifications are without any(!) benefit as long as speaker-impedance doesn't drop significantly below 4 Ohm (and even in that case the audibility is debatable, of course). Usually the 405 is not recommended for this kind of low-impedance-loads -- but have a look ... I did this mod for curiosity-reasons only, and it works nicely indeed. But it requires some 'hard work' and is a pleasure only to her (or him) who enjoys opening the toolbox (purists should skip the rest of this section to avoid heart-attack!).

To get more current with less distortion, you can upgrade each single output-transistor (17556, 2SD424 -- or even the veteran BDY77) by a pair (yes: a pair!) of up-to-date-devices. Doubling the devices will give safer and better performance with low-impedance loads because each device will work at half the current (where their current-gain is higher) and resistive losses are reduced as well. Thanks to the uncritical class-C design of the dumper-stage (no quiescent current) this upgrade is no problem electrically (as the 606-family shows). Mechanically it has become rather easy thanks to the new TO-3P(L)/TO-264 'plastic'-packages for power-semiconductors.

A state-of-the-art choice for upgrading might be Toshiba's recent 2SC5200 (or 2SC5359) which replaced the recommended 2SC3281 in ~1997 (be careful: by now most devices offered as "Toshiba 2SC3281" are just fakes - something like 2N3055s in TO-264-cases!). Motorola's improved copy, MJL3281A, seems to be still in production, and recently ON-Semiconductors introduced the MJL4281A. They all

have nearly constant dc-current-gain of about 100 from 10mA up to ~7A (with the older types gain drops from about 50 at 3A to less than 30). But unfortunately they are very fast (CGBP ~30Mhz) and thus not wholly uncritical. There is no benefit from increased dumper-speed here, on the contrary: if the dumpers open too fast, the class-A stage may be too slow (due to C8) to react in time. Test for overshoot with 1kHz square-wave. Usually ~1nF (ceramic) from collector to base of Tr10 (like C19 in some issues of the 405-1) will help already. (If you are lucky, C19 and R41/L3 are present on your board [sn. 9000 to 59000]; this will put you onto the safe-side anyway).

Motorola's MJL21194 and 21196 (a kind of improved 15024) are more conservative alternatives: They are not that fast (CGBP ~7MHz) and they show nice current-gain characteristics up to 5A as well (which is, obviously, more than ample, at least with double-output-devices). 'MJ' indicates TO-3 at Motorola, 'MJL' is TO-3P(L)/TO-264, so look for the 'L' here, since all are available in 'classical' TO-3 as well. Maybe even some TO264-versions of MJ15003 are (or will be) available.

The new TO-264s obviously don't fit into the old places, but there is an easy way to mount a pair of them: Remove the two old TO-3-devices and place the first two of the four new TO-264 next to the PCB-borders with the pins pointing right and left into opposite direction. Drill two additional 4mm-holes for the screws (there is enough room in this area of the PCB).

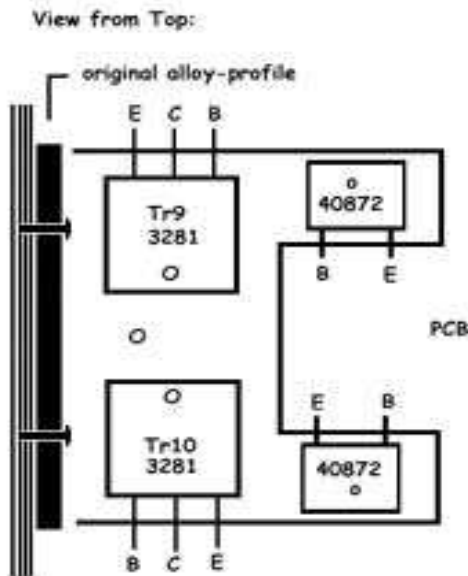

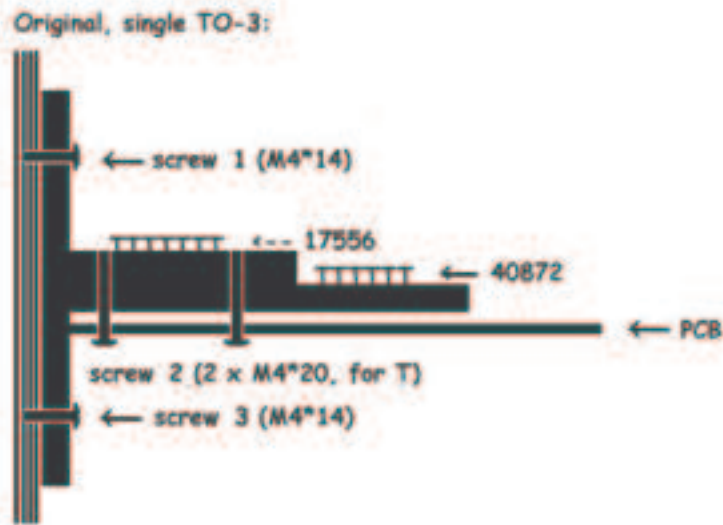

The second pair can conveniently be mounted on top of the first. To insure proper cooling, add a small aluminium-profile (2cm+3cm, ~8cm long, 3mm or 4mm; with 4 suitable 4.5mm-holes for the screws):

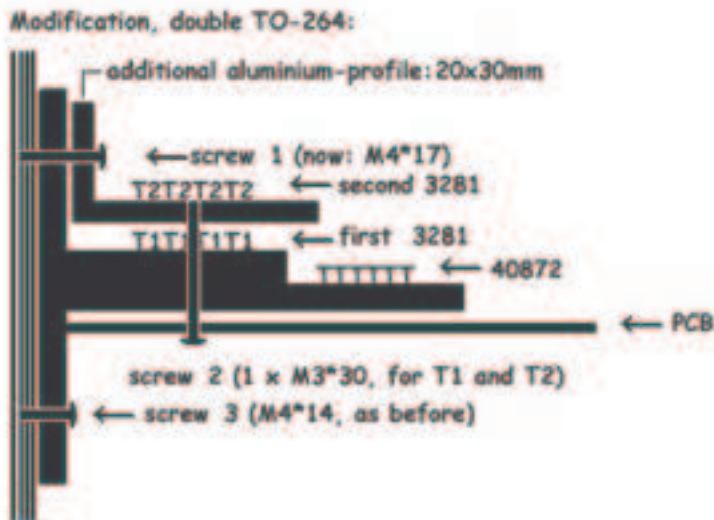

Mount the 3281s (resp. their successors) close to the 40872-side to leave enough room for screw_1. Place the lower two (T1) first, then add the profile with screw_1, then the upper two (T2) and at last screw_2 (the nut on top of T2). All transistor-packages must be insulated with suitable pads and heat-transfer-compound has to be used (even between the profile and the top of T1). To my experience the cooling of all four devices is excellent then.

Connect collector and base from T2 to those of T1 and then both by short links (across the border of the PCB) to the copper-pads of the PCB (a common 10R/2W base-resistor is recommended, see C5) below). Connect each emitter by 0.1R/2W for reliable current-sharing (so it will not be necessary to match the pairs precisely). Use insulation tubes on all links!

c) Current-limiter, Step 2: Thanks to the output-pairs you can allow a maximum current of ~10A (=100W into 2 Ohm and 200W into 4 Ohm) and a short-circuit-current of ~5A (I don't think that further increase of the maximum current makes any good sense). In the 405-1 reduce the 0.091R (.08R, < sn. 29000) current-sensing resistors (R35/36) to about 0.06R by soldering 0.22R/1W (0.27R/1W) across. In the 405-2 two 0.82R/1W resistors across R35 and R36 will reduce them from 0.18R to ~0.15R; this will allow ~10A instead of ~8A.

The 405 will stay protected against all kinds of electrical short-time-stress after these mods. But long-time overload or even short-circuit (with input-signal applied) will kill it thermally (that is, of course, the same as with the original limiters). Since this will take some time it can usually be avoided by the careful user.

And if you don't like current-limiters at all (but why?): just short-circuit e-b of Tr5 and Tr6 [405-1] or R35 and R36 [405-2]. Then the limiters are absolutely out of operation and hence there is no further improvement possible by removing any of the components (as long as the current-limiters themselves are not broken, of course)! You may thus add a simple current-limiter-switch onto the PCB temporarily if you want to try whether there is any audible influence at your listening levels (but keep all wires as short as possible!).

Since second-breakdown limit of a pair of 3281s at 50V is < 8A, a simple voltage-independent 10A-protection is not sufficient for short-term short-circuit-safety; so removing R27/28 [in the 405-1] is not very useful.

I admit, this double-3281-output-stage looks more like a re-design ('505'?) than a mere modification of the 405. Due to the high current-gain of the 3281s (and their successors) it might nearly match the current-capabilities of the 606's triple-17556 output-stage now. Since the driver-stages of both amps are almost identical (see C1 below) and the 405 power-supply is not too poor (2*10.000uF [405] instead of 4*6.800uF [606; in the 707 the PS-caps were increased]), the low-impedance-performance of the modified 405 should come rather close to that of the 606 (but observe C5 below!). The 520f (a precursor of the 606) has a double-17556 output-stage (and 4*6.800uF PS), the smallest member of the family, the 306, has single output-pairs (and 4*4.7000uF).

C) MISCELLANEOUS

(In Sum: One diode and a resistor should be added to the 405-1, see C5 & C6 below)

Here are Quad's own updates in later 405 versions; probably most of these improvements are far below audibility, but why not be on the safe side? (See Appendix IV below)

1) [405-1] If R23 is 1k2 (not 3k3 as it was in SN < ~1500) then C11 should be ~1nF (not just 330p); so add 680p across C11 (the smaller value dates from early versions where each of the low-voltage 'pre-drivers' had its own collector-resistor and -cap). It is also possible (but not necessary!) to 'upgrade' to the straightforward '606-solution': Replace the two ZTX504 (Tr3/4) by high-voltage-types MPSA93 (or 92 -- observe EBC pin-layout!) and connect both collectors directly to that of the 40872 (that is, short-circuit C11 and remove R23: their only task was to keep off the high-voltage

output-swing from the low-voltage pre-drivers and to couple all the collectors in the ultrasonic range [for speed and stability] at the same time).

2) [405-1] Before Sn. 59000 the feedback-capacitor (C8) was connected to the collector of the current-source (T1). The more adequate point (with respect to bridge-balance) seems to be the collector of the input-transistor (T2). Just connect C8 to the opposite end of R17/C7 (that is: to the end more close to the output-device-side of the PCB): One 'cut' next to C8 and one new link with ~1cm of insulated wire.

In 2004 Keith Snook proposed to connect C8 to the emitter of T2 (like in the 306/606). His measurements indicated further reduction of distortion, even with the original bridge-components, so this seems to be an even more consistent mod. I didn't find the time to try it, but I recommend it nevertheless.

I do not think that replacement of C8 by another type will make sense, but this is debatable, of course. [NB: There was a huge power-on-bump and a soft power-off-'crackling' in one channel of a 405 I bought second-hand some time ago. The cause was a faulty C8 which measured ok, but obviously allowed some small DC-break-through which was sufficient to open Tr3 as long as the current-source Tr1 was cut off at start-up and shutdown. After replacing C8 everything was ok!]

3) [405-1] In these pre-59000-versions C5, R14, R15, R18 and R22 were connected to the emitter of TR5. But they all should be on the same potential as the emitter of TR7 (otherwise there is some unwanted feedback via R35 -- a serious layout-flaw, also to be found in the 520f and in early 606 issues!). -- According to the schematics it looks as if you only had to cut the link between R22 and TR5 (emitter) and connect R22 to TR7 (emitter). Unfortunately things are a little more complicated in real life. # But now there is a very elegant solution nevertheless (it was submitted by P. Nunes SP, Brazil):

- 1) Just lift off: a) the emitter of TR5 (i.e., remove TR5 and resolder only the base and collector of it, leaving the emitter out of the appropriate whole), b) the corresponding end of R35 and c) the positive supply wire (red). 2) Solder a+b+c together on a small metal strap (on the component side, of course!). 3) Link the former soldering-pad of the red wire to the opposite end of R35 with ~1cm of insulated wire (on the copper side). That's it: The job is done in a straightforward way without having to cut any track.

Thanks!

The only drawback of this simple solution is that now R7 has moved to the wrong end of R35 (like in the 405-2). So it will sense about 0.3V "signal-induced-ripple" in addition at full current-output. But I think the zener (together with the new caps and the OpA's power-supply-rejection of about 100dB inside the audio-range) will compensate for that easily. If you disagree with me (and with Peter Walker), you might want to change this as well.

4) [405-1] Later, two diodes (1N4003) were added across e-c of the output-transistors to protect them against reverse-voltage due to clipping with inductive loads. They are not intended to have any influence during normal operation. Add them if you want to drive the 405 to its output-voltage-limits -- or if you want to be on the safe side anyhow.

5) IMPORTANT! [405-1 / early 405-2] To improve the voltage-transfer- characteristics of the unbiased class-C dumpers (i. e. to unburden the class-A-stage) Quad in later versions of the 405-2 (and in the 520f- / 606-family) added one diode (=+0.6V) between the bases of Tr8 and Tr9 (they called it D13. This reduces distortion especially at low levels and high-frequencies further and should ABSOLUTELY be applied to every 405-1 (see Appendix F1 below; in the first 405-2s (PCB 12565.6), D13 was not yet introduced, but the base of Tr9 was connected to the opposite end of D6, this is not yet perfect, but sufficiently close to).

There is a straightforward way to add the diode to the older 405-1 PCBs (thanks, Keith Snooke – my own proposal was much less elegant!): [1] Remove D6 and replace by two diodes (D6 and D13, 2*1N 4003) in series, same 'direction', mount these onto the copper-side of the PCB. [2] Cut the PCB-track from Tr9's base to D6 (best: about 5mm from the soldering point for the base of Tr9). [3] Now connect the base of Tr9 by a short insulated wire (or, even better in terms of stability and bridge-balance at crossover, by a 10R/2W-resistor -- like in the 606) directly to the junction of D6 and the new D13. That's it!

6) [405-1 / early 405-2] In even later versions of the 405-2 a 75R resistor was added across the output-inductor (L2). This was -- probably -- for compensating some unwanted increase of inductance at higher frequencies (caused by Eddy-currents in the small coil; see JAES Jan. 1980, p. 12). It may be added because it is supposed to improve the rf-balance of the feedback-bridge.

D) LAST NOT LEAST (power-supply)

(In sum: just a little more rf-decoupling)

A 330nF/400V cap across the mains will reduce influence of noisy power-lines. 470nF/150V from each of the transformer's outputs to ground (yellow to green) helps further against noise from transformer and rectifier [from 606]. The 405 should be absolutely insensitive to thermostats and other noisy devices then (mine is).

The wires from the secondary-windings of the transformer to central-ground (green) and to the rectifier (yellow) can be led directly from top of the transformer to rectifier and caps. So they will be as short as possible and more remote from the signal-wires which minimises influence by radiation (this is the only reason for any mod here; it is, of course, a waste of time and money to replace these short wires by "better" ones since resistive losses inside the transformer are dominant by far). The original 'cable-tree' is preferable from the production-process perspective only.

The 10.000uF/63V power-supply caps should be replaced after 10 to 15 years of use because they become noisy by the time. This noise is not directly audible but it makes distortion increase. Electrolytics in power-supplies have a lifetime of less than 10.000 hrs. when exposed to higher temperatures (as in the unventilated 405-case). Since electrolytics have become better, cheaper and MUCH smaller since 1975 (there is real progress in this area!) some 15.000uF/63V-devices will fit now (so the 405 will have the 606's power-supply-capacity). Maybe even 22.000uF are possible, but I am not sure whether every rectifier will survive their much higher start-up-current. Some people uprated to 22mF without problems, but there is a risk in it

nevertheless! So you should not try it before you know some suitable replacement for the rectifier which fits into the case (this might be a problem -- I didn't look for a replacement yet).

Decoupling the power-supply-rails on each PC-board not only with 100nF but with 100uF will reduce resonance-effects due to the inductance of the wires from the PS as well as mutual interference between the channels via PS (class-B and class-C output-stages send much switching noise 'back' into the rails). Add 100uF (or 220uF)/100V across C15 and C16, this will be more effective than rewiring the whole PS! [from 606] You should check PCB-layout: On iss. 12368.10-boards the grounding of C15/16 is separated from the signal-grounding on the PCB. If this should not be the case with other issues, I would recommend replacing the PCB-ground-connection of C15/16 by an extra wire to the central ground-connection (at the screw next to the output-devices). Otherwise the signal-ground might be polluted by the output-stage rubbish.

E) TO SUM UP:

Simple replacements or add-ons:

Op-amp:

IC1	TL071	replace by NE5534, OpA604 or -
or	LM301	and add supply-decoupling --> (+)

Diodes

D1/D2	change from 12V to 15V (SN below 29000)
-------	---

Resistors:

R4	22k	add 10k across to reduce gain (*)
R6	330k	add 150k across to reduce gain (*)
1x	75	across L2 (3uH)

Caps:

C2	100uF	[see section A2) about gain-reduction]
1x		add 100nF polypropylene across C2
C4	.047uF	100nF MKT across to reduce gain (*)
C5	100uF	replace after ~10 years and in case of hum
C10	47uF	replace after ~10 years
C11	330pF	[if not already 1000pF add 680pF styro across]
C13/14	10000uF	replace after ~10 years
C15/16	100nF	add 100uF/63V across (observe polarity!)
2x	-	add 100nF from OpA supply pins to ground (+)
1x	-	add 330nF/400V across mains
2x	-	add 470nF/150V from transformer outputs to ground

(*): Standard gain modification by factor 3.

All these mods (and even those of section B above) can be applied without removing the PCBs. You only have to remove top, bottom and sides of the case (which is very easily done) to reach the relevant locations. (Take care: High voltage circuitry!!! Never!!! approach the open case when the power-plug is in the socket!).

If you have the new components at hand, a complete 'sonical update' even of a first-generation 405-1 will not take much more than an afternoon. If you are not yet an expert, do it step by step, trying each mod on one channel first and applying it to the other only after it succeeded on the first (if you use your precious speakers for these tests, add about 50 Ohms/10W in series, to protect them). This will take only little more time if everything works well -- and will save very much time and money if something goes wrong.

With the exception of the PS-electrolytics (>> €10 each) everything is VERY cheap: Resistors and caps don't count since there is absolutely no need for any precious or exotic components (that's the offspring of a sound circuit-design -- and thus QUAD never cared much about components, except for reliability), an OpA604 is about €3, a NE5534 not even €1.

And if you need 'low-impedance-power': Even the 5200s or 3281s are available for less than €3.- each (but you'll need 8 of them, of course -- and much more time and skill).

Last not least: You are free to replace some components by 'audiophile' parts and to rewire power-supply, input- and speaker-terminals with some so called "high-grade" wire. This will be the only modifications which may become really expensive. Replacement of the connectors makes some sense in respect of convenience (take your pick). But replacement of wires is entirely futile. Don't forget: most of the wires in the chain from the first microphone up to your speakers are not at all 'audiophile' (but just 'professional') and only a very small fraction of them is inside your own audio-gear. Hundreds of feet are passed through inside the recording studios before the signal reaches the mixing console, several feet of "visible" line cables, a mostly unknown amount of "invisible" wires (like PCB-tracks or pins of discrete components) are inside the recording-, mastering- and play-back-equipment, at least 5-10 feet of wire run from the amp's to the speaker's terminals, plus some inductors in the cross-overs and -- chiefly -- about 10-20 feet (ultra small-gauge: they sum up to several Ohms!) wires of the voice-coils.

I wouldn't expect anything (sonically, of course!) from rewiring far less than 1% (0.1%?) of that chain (by wires whose relevant specs differ probably less than 1% (0.1%?) from those of the standard parts) -- but it's a harmless pastime anyway (as long as your amp doesn't smoke afterwards!), and the only restriction is your personal budget. But keep in mind: Professional "high-end"-manufacturers use "premium"-components mainly because they found out that their products SELL better. And they are in fact right, since their customers erroneously believe that the manufacturers did it because they found out that they SOUND better. In a recent Audio-Magazine the readers were indeed "informed" (by testimony of a colour-photograph taken from the opened speaker-cabinet!) that the last foot of wire which ran from the terminals to a crossover-coil (the latter of several ohms resistance and—of course—significant inductance!) was an expensive "high-grade" (that is: low-resistance, and low inductivity). If YOU were a manufacturer who wants to sell audio-gear in these foolish days, would you expose a "cheap" wire to the eyes of your unsuspecting customers, even if you were absolutely (and by right!) convinced that it would do a perfect job there?

Hope that helps, good luck -- and trust your ears: You will notice that an expiry date for the current-dumping principle is not yet in sight (although even QUAD dumped current-dumping by now)!

Don't get my above proposals wrong (as at least one correspondent did!): They aim at improving the 405 (and at having some fun), not at creating a perfect amp. If someone tells you that the best upgrade of a 405 is to sell it, [s]he may be right, of course! Don't contradict, just buy the 405 at the low price [s]he thinks it is worth — and unpack your soldering-iron!

Corrections, criticism, further suggestions welcome!

BL

Appendix I:

How does the 405-circuit basically work?

(For the beginner — I hope I got everything correct myself. Corrections welcome!)

The simplest way to describe the function of a transistor (PNP and well as NPN) is the following (I'll explain just the NPN-case = Tr2 in the 405, PNP works identically when all voltages are inverted):

Assume that a voltage of more than, say, +2V is applied between collector and emitter. A current flows from collector to emitter only if the voltage between base and emitter (called 'Vbe') is $> +0.6V$, otherwise the c-e-path is cut off (hence a transistor is an electronic switch). When the transistor is open the current $c \rightarrow e$ is much bigger than $b \rightarrow e$ ('high current-gain') and $c \rightarrow e$ -current changes heavily when Vbe varies only slightly around the 0.6V-limit ('high transconductance') while it is rather independent from the $c \rightarrow e$ -voltage. Often an 'inverted' point of view is helpful: Whenever the c-e path of a transistor is conducting, the voltage between its base and emitter is $\sim 0.6V$. This may be considered as the 'b-e diode': since when a diode conducts (in direction of the arrow) there is a voltage-drop of 0.6V across it as well. This voltage-drop is rather current-independent; but in case of power-devices, Vbe will rise up to 1.5V with current (as a rule of thumb: always assume about 0R1 inside the package in series with the emitter).

To the 405 main-circuit now:

At first ignore L1, L2, L3, (L4), C7, C8, C11, R17, R23 ('remove' these Cs, 'short-circuit' these Ls and Rs). They all are there for rf-stability only. Further ignore the current-limiters (Tr5, Tr6 and those resistors/diodes connected to their bases); they will be treated separately below.

For the sake of simplicity of argument further assume a 450R-resistor (called Rc now) from the base of Tr3 to the positive rail. It replaces the current-source (Tr1, R13-15 and C5) for the time being.

Now look at Tr2 first: Assume its emitter is at a given voltage-level. When its base-voltage Vin (the input) rises above this emitter-voltage by $\sim 0.6V$, Tr2 opens (see above) and thus draws a collector-current 'I' from Rc. Consequently the voltage V at the base of Tr3 will drop from +50V downwards (by $V = Rc \cdot I$) and Tr3 will open (at $V_b = 50 - 0.6 = 49.4V$). As long as nothing else happens, current (through Rc and

through R13 now as well) will rise further until the base of Tr4 is at 49.4V -- and now Tr4 opens (you will observe that the base of Tr3 is at 50-1.2V in the meantime: 0.6V voltage-drop at each b-e-diode). Since nothing else happens, current will rise even further until Tr7 opens. By now we have got: b of Tr7 at 50-0.6V, b of Tr4 at 50-1.2V, b of Tr3 at 50-1.8V -- the collector-current of Tr2 will be about 4mA thus $[1.8V/450R=0.004A]$. — Using the 4mA current-source (Tr1 and paraphernalia) instead of $R_c=450R$ doesn't change anything in principle, but it dramatically increases loop-gain (and thus reduces distortion): The same change of the c-e-current in Tr2 results in a change of V_{be} in Tr3 more than hundred times higher than with the 450R resistor.

When Tr7 was closed, the voltage at its collector was $\sim -50V$ (because the collector is connected by R30/31 to the negative rail -- ignore the diodes for the moment); and when Tr7 is completely open, its collector is at $\sim +50V$ (because the c-e resistance is very small then -- call it zero -- compared to R30/31).

When Tr7 opens just a little (that's what we assume now), a current runs down R30/31 and generates a voltage-drop V . When this current is $\sim 45mA$ the said voltage-drop across R30/31 is $V = I \cdot R = 0.045 \cdot 1k12 = \sim 50V$, which means ($-50V+50V=0V$): the collector of Tr7 is next to the zero-volt-level then (which will be the case when the amp is idle -- and $\sim 45mA$ is the 'idle-current' thus). Let's now ignore Tr8-Tr10 (the dumpers-section). The output of the amp is fed only by R38 then.

At this point negative feedback comes into play: The amp's output is connected 'back' to the emitter of Tr2 by R20/21 (and L2). What happens thus when Tr7 opens? The R30/31-current rises and so the voltage at the output of the amp -- and with it the voltage at the emitter of Tr2 (via R20/21). But when this voltage rises, the voltage-difference between base and emitter of Tr2 decreases. And when this difference approaches 0.6V, Tr2 tends to close. But then its collector-current reduces and (see above) Tr3, Tr4, Tr7 will reduce their current too: the output-voltage will thus stop rising.

At which voltage? Due to R20/21 and R16 the voltage at the emitter of Tr2 is exactly $180/(500+180) \cdot V_{out} = (1/3.77) \cdot V_{out}$. So: when $V_{out} = 3.77 \cdot (V_{in} - 0.6)$ the voltage between base and emitter of Tr2 will be just as big (0.6V) as to open Tr2 sufficiently to allow the current that opens Tr3...Tr7 suitably. If the base voltage of Tr2 will increase by 1V the output of the amp will rise by 3.77 Volt (and everything will be stable again at this value). If the base-voltage will decrease by 1 Volt, the output will drop by 3.77V. -- This is a simple, non-inverting, single-ended small-power amp (with a voltage-gain of 3.77), and since Tr7 never shuts off during the full output-swing (from ~ -45 to $\sim +45V$) it operates Class-A.

What does the OP-Amp do? Two things: Firstly it gives additional amplification of the input-signal: ~ 15 in the original, so there is $15 \cdot 3.77 = \sim 56$ overall gain. Obviously the main design-idea in the 405 was to add a CD-output-stage to an OpA. Since the OpA is assumed to give an undistorted output-swing of about $\pm 12V_p$, the CD-stage's voltage-gain had to be about 3.5 to give a suitable output-voltage for $\sim 100W$ into 8 Ohms ($=40V_p$). Since OpAs are indeed excellent voltage-amplifiers (at least nowadays), it was a nice idea to reduce the voltage-gain of the CD-stage as much as possible and to leave all the remaining voltage-amplification to the op-amp.

Secondly the OpA is responsible for DC-feedback (R5/C2 keep the audio-signals off, so only the DC-level of the output reaches the inverting-input of the OpA). It adjusts its own output (and with it the base of Tr2) to give 0V at the 405-output when no signal is present (so offset depends only upon the offset-parameters of the OpA -- which are excellent by themselves [$\ll 5\text{mV}$, small drift]). Since idle current through Tr2 is $\sim 4\text{mA}$ (see above) when the output is at zero, the voltage at the emitter of Tr2 is $R_e \cdot 4\text{mA}$ with $R_e = 130\Omega (= 180 \parallel 500)$, so $V_e = 0.53\text{V}$ and the OpA will thus set V_b of Tr2 to $0.53 + 0.6 = 1.13\text{V}$ for zero-output (in the 405-1 the current-source delivered $\sim 6\text{mA}$ [R14 was 0k56, not 0k47], so V_b of Tr2 was $\sim 1.4\text{V}$).

Now to the dumpers; positive output-swing first: Tr9 opens when its base is 0.6V above its emitter (= the output of the amp). Since there is a voltage drop of 0.6V at each of the two diodes (D5/D6), Tr9 opens not before the collector of Tr7 is $0.6 + 2 \cdot 0.6 = 1.8\text{V}$ above the output, that is when a current of $1.8\text{V}/47 = 38\text{mA}$ runs down R38. From then on any further positive current will be 'dumped' by Tr9, and the small class-A-amp (Tr7) has only to supply the current through R38 (38mA), the base current of TR9 (which is $< 1/30$ of the speaker-current) and the idle-current through R30/31 (45mA). This is less than 300mA altogether at full output. Thanks to 'bootstrapping' by C10 there is hardly any AC-current from Tr7 into R30/31.

And finally the negative swing: When the speaker-current through R38 becomes less than 12mA , the collector of Tr7 is less than $0.6\text{V} (= 12\text{mA} \cdot 47)$ above the output and thus the base-voltage of Tr8 (PNP) is -- thanks to the two diodes (1.2V) -- more than -0.6V below the output: Tr8 opens and speaker-current will thus be just the difference of the currents fed by Tr7 and Tr8. When the latter's collector-current then rises 'above' -27mA , Tr10 opens as well ($27\text{mA} \cdot 22\Omega = 0.6\text{V}$) and 'dumps' any further negative current. Thanks to the two diodes the collector of Tr7 is still $\sim +0.6\text{V}$ above the output when Tr8 is open. Consequently Tr7 (the A-stage) will always control the speakers.

Since the dumpers Tr9 and Tr8/10 switch on and off during a voltage-swing and since there is a small gap (V_{be} of Tr8+Tr9 = $\sim 1.2\text{V}$) where both of them are off, they work 'Class-C'. In 'Class-B' there is always a small current (the quiescent/idle-current) that runs through at least one of the two devices -- and this improves linearity drastically. This idle-current can be determined -- to illustrate it at the 405-example -- by a voltage applied between the bases of Tr9 and Tr8, the 'bias-voltage' (1.2V by two additional diodes for example, then Tr9 would open just when Tr8 closes -- vice versa). The reason for using 'dirty' class-C in the 405 is that class-B requires additional design-care and adjustment of each individual amp because V_{be} is device-dependent and (at least in bipolars) further drops with temperature from $\sim 0.6\text{V}$ (at 25C) to $\sim 0.3\text{V}$ next to the working-temperature limit ($\sim 200\text{C}$) of the transistors. So the quiescent-current in class-B heavily depends on temperature if no special thermal-control of the bias-voltage is added. And the bad thing is: when the amp warms up, V_{be} (of bipolars, not of FETS) goes down, hence the current rises and so the amp will warm up even further and consequently V_{be} goes down further ... (that's 'thermal runaway').

One diode (D13 -- just one, not two!) was added in the later 405-2 (and in the 606-family) between the bases of Tr8 and Tr9. It pushes the base of Tr9 up by 0.6V , so the voltage gap (where both Tr9 and Tr8/10 are closed and Tr7 alone has to control the output) is reduced from 1.2 to 0.6V (at room-temperature) and the current

through R38 is further increased by 12mA. This makes error-cancelling much easier for the class-A stage (especially with low-impedance-speakers), and nevertheless thermally unstable 'class-B' operation will not appear before the temperature-limit of the output-devices is passed anyway. Although I don't know whether it is either measurable or audible: The 405 'improves' in principle when it warms up, since its dumpers approach a class-B-output-stage more and more. Consequently a 'hot' 405-2 should sound best and a 'hot' 405-1 (without D13) should sound just like a 'cold' 405-2. -- NB. Whenever any kind of 'warming-up' improvement is audible in a modern class-B (or -AB) power amp (or, even worse, in a preamp), this reveals very (! yes: very!) poor design since many simple means have been developed in the last 30 years to eliminate all the effects due to these slow changes in temperature. The only parameter-change with temperature which cannot be easily compensated for is current-gain of the output-devices, but no serious design will be sensible to these changes anyway (in OPAs, the most prominent specs that change with temperature are slew-rate and GBW which normally decrease(!) by 10% after warming up [increase of input-bias-current and -offset play no role in any sound audio-design]). So every state-of-the-art solid-state amp should be perfect at low temperatures as well (that is, about 5-10s after power-on). Only fast changes of junction temperature (and hence of V_{be}) of the power-devices, caused by the dynamics of the programme-material, are a serious challenge until nowadays (because they are a bit difficult to monitor in "real-time"). -- Current-Dumping deals with both of them at the same time: Crossover-distortion is not reduced, but it is cancelled by the class-A stage!

Protection-circuitry

1) Current-limiter (405-1, positive rail, negative rail similar; 405-2 is a little more sophisticated but not different in principle; help yourself—maybe after some inspiration from B2a above!): R35 monitors the output-current. When this rises to ~7A, the voltage across R35 (.091R) and hence across V_{be} of Tr5, rises to ~0.6V. Thus Tr5 opens and this short-circuits the input of Tr7. When the output-voltage is zero (that is: the voltage across Tr9 is ~50V), then R26/27 add about further 0.25V (=50V*75/15k) to the voltage across R35, hence only 0.35 V across R35 (= ~3A) will already open Tr5. For any output-voltage between 0V and 50V, the current-limit is somewhere between 3A and 7A. Thanks to D3 and R24 the max. voltage across R26 is $75/(22+75)*0.6V = 0.46V$, so Tr5 will only open when at least additional 0.14V appear across R35 (this prevents the protection from switching on and off when the output voltage becomes negative).

2) DC-clamp (in earlier 405-1 on extra PCB at speaker-posts): R42/C17 form a ~1Hz low-pass to the bipolar switch T1 (third pin not connected) which triggers the triac T2. When DC-voltage across T1 is > 5V (positive or negative) T1 breaks through and hence the triac opens and short-circuits the output. Then one of the rail fuses will blow (and not the voice-coil of the woofer).

Appendix II:

The Current-dumping-principle (CD).

Here is just a 'thought-experiment' to get an idea of the CD-principle in the 405 (see 'Electronics and Wireless World' (EWW), June/July 1978 and 'Journal of the Audio Engineering Society', Jan. 1980 for further details):

'Remove' C8, R38 and 'short-circuit' L2. This will give a fictitious next-to-perfect conventional ultra-high-feedback (via R20|21) amplifier with ample of (call it: 'infinite') loop gain and thus extremely small (call it: 'zero') distortion (even with a crappy class-C output-stage!). But, of course, this amp is impossible in real life because it will be unstable due to limited bandwidth of -- and thus to phase-shift by -- the output-stage (otherwise audio-amp design would just be a child's play -- the 'Current-Dumping Review' in EWW Sept/Oct. 1983 f. e. ends up in absurd conclusions because it completely ignores the stability-problem; see Peter Walker's reply in the December issue).

So you will have to add C8 again as a compensation-cap (nearly every amp -- Op-amps included -- has a cap like this in its voltage-gain-stage, usually in a place that corresponds to c-b of Tr7 [the 'pole-splitting-capacitor']). Assume -- just for the sake of the following illustrations -- C8 were connected to the emitter of Tr2 (not to its collector [and to the base of Tr3] as it actually is). This makes no difference in principle as long as R12/C6 limit input-bandwidth sufficiently (hence C6 is ABSOLUTELY required, otherwise the source-impedance for Tr3 would be too high at rf, and thus overshoot or ringing were to be expected). C8 will reduce loop-gain of the driver-stage at high frequencies (by -6dB/oct), and consequently give a stable, but now only mediocre real-world amplifier: Overall loop-gain is too small now to reduce output-stage distortion adequately, and the two 'feedback-paths' (via R20|21 and via C8) are not matched as well, so reducing the output-stage-distortion to zero by feedback is impossible even in theory. Conventional engineering thus tries to improve the output-stage itself (f. e. by sophisticated AB-biasing-techniques) to make distortion reduction by feedback less urgent.

In 1975 Albinson/Walker invented a different (the CD-) solution: Adding R38 and inserting L2. If the 'square' formed by C8, R20|21, R38, L2 (the 'bridge') is balanced according to $L2 = R20|21 * R38 * C8$, the voltage at the emitter of Tr2 (C8,R20|21) is always strictly proportional to that at the output (R38,L2): Overall [!] feedback is absolutely perfect now at any frequency, even with the unavoidable compensation-cap C8 in its place, and stability is further improved by L2. If the output-stage tends to distort (especially at crossover), the fast class-A driver (Tr7) will fill in the suitable correction-signal via R38, and thus the poor voltage-transfer characteristics of the class-C 'dumpers' has no influence on performance at all -- as long as the driver is not overloaded, of course. Consequently the quality of the amp depends exclusively upon the linearity of the class-A stage (Tr7) and upon bridge-balance. It is thus -- at least in theory -- possible to get a stable, zero-distortion power-amp even with a very robust and "dirty" class-C output. To give a slightly different picture: The class-C dumpers carry the output into the target-area of the low-power 'single-ended-class-A-stage' -- and the latter 'makes the sound'. This was indeed the way the 405 was advertised by Quad. But it is important to note that nevertheless the CD-principle is above all a means to compensate for the unavoidable "compensation-cap" (C 8): With a purely resistive "bridge" Current-Dumping would be entirely pointless. But when the voltage-gain-stage is an integrator (as it is necessarily in ANY amp, just for stability reasons), the bridge-component between the dumpers and the speaker will

be a small inductor which has no relevant effect inside the audio-range: Then CD has indisputable merits.

In practise some (trial-and-error-)trimming of the bridge was necessary due to C8's move from Tr2's emitter to the collector (maybe for further increased stability?), the finite conductance of Tr7, the limited current-gain of the dumpers near crossover, the presence of R12, R30, C10 etc. etc. For these -- and/or other -- reasons there seems to be a ~10% correction to be found in the 405-design: $0k5 * 0k047 * 0.12nF = 2.8uH$ (not 3.0uH as indicated in the circuit-diagrams). Quad used 5%-components, so residual bridge-unbalance will be less than 10%. This is not very much since distortion actually seems to be affected by about the same order (hence ~0.011% instead of 0.010% f. e.), and this was reasonably supposed -- by the Acoustical Mfg. at least -- to be inaudible (just don't overlook: even with L2 short-circuited [= 'infinite' unbalance!] distortion is still below 0.3% [up to 10kHz!, compared to < 0.01% at optimum balance]). -- Of course, if you can measure crossover-distortion precisely (by scope or spectrum-analyser f. e.), you might try to adjust C8 or R38 of each 405-channel individually for the last grain of improvement (for example: 4.7pF across C8 or 1k across R38 will affect bridge-balance by about +-5%). Do not change R20/21 since they affect the overall gain and thus stereo channel-balance as well.

There exist a popular east-European DIY-clone of the 405 which uses two Darlingtons in the output-stage. One BDX65 for TR9 and one BDX64 for the TR8/TR10-pair (a nice idea). It uses the original resistors in the bridge, but 2.3uH and about 150pF. This is definitely wrong (a bridge-unbalance of about 75%)! With a 2.3uH inductor the feed-back cap has to be 86pF! (Obviously the designer erroneously increased the 120pF cap by 3/2.3 instead of reducing it by that very factor.)

Appendix III:

A note on SLEW-RATE and BANDWIDTH

A large C8 (and with it a large L2) increases stability -- but at cost of power-bandwidth and/or slew-rate: C8 has to be charged and discharged correctly at each cycle. Charging C8 from the output is no problem, since impedance is negligible. It is the positive input-side alone that sets the limit: With 4mA (405-2) from the Tr1-current-source the maximum positive loading-rate for C8 is: $4mA/0.12nF = 33V/us$ (hence the slew-rate is not limited by the drivers or the output-devices, but by C8 and the current-source alone; however, the speed of the output-devices determines how much compensation (C8) is required for stability). For a 1-Volt change at the output (8 Ohm-load, R38=47, worst-case: dumpers are off) the collector of Tr7 has to change by $(47+8)/8 * 1V = 6.8V$. Hence the slew-rate limit of the 405-output into 8 Ohm is $33/6.8 = \sim 5V/us$. The 405-2 was thus correctly advertised for ~0.1V/us max. input slew-rate. This looks meagre compared to any modern FET-power-amp, but nevertheless this is exactly what is needed for an undistorted, maximum-level 20kHz sine-wave, and this in turn is the fastest undistorted signal today's 44.1kHz-CD-players can deliver to the amp without overloading it: Every complex signal with 20kHz-bandwidth is either 'slower' than the full-output 20kHz-sine-wave (simple math!), or it has higher amplitude and will thus drive the amp into clipping anyway. With this "speed" the 405 is at least 10 times faster than required for all relevant programme-material imaginable (high-end-mythology aside, of course). And this will not change if we turn to higher sampling-rates in future--as long as the amp is used for music only, of course. Note that any OpA that works perfectly up to ~1.3V/us(!)

will do it in the 405 input-stage. Hence any bare slew-rate figures from the OpA-data-sheet beyond a safety margin of, say, $\sim 5\text{V}/\mu\text{s}$ are definitively pointless! Sonical differences with ultra-high-speed OpAs (if there are), will call for other explanations.

Since all QUAD-Amps are bandwidth-limited by a $\sim 10\text{Hz}$ high-pass and a $\sim 50\text{kHz}$ low-pass (here: C2/R5, C6/R12), square-wave-performance does LOOK very strange when observed by scope. But as long as there is no overshoot or ringing, these visible 'deformations' have nothing to do with (non-linear) distortion and are thus definitely inaudible. Maybe there are DC-coupled-amps with about 1MHz -bandwidth that sound different from the 405. If they actually do, there might be many reasons for that but it definitely has nothing to do with those "deformations" that appear in the square-wave-images. As recent AES-research has shown, ultrasonic signals ($>20\text{kHz}$) are audible ONLY if (and only *because*) they produce audible intermodulation-distortion in the speakers. Since all real-word speakers are sufficiently non-linear to add audible intermodulation-products it is important that only those signals are delivered to them which are audible by themselves. Otherwise we just hear distortions even without hearing the "real thing" behind which causes it. So IF the low-pass in a QUAD has any audible influence at all, this will be sonically beneficial. -- The same applies to the high-pass as well.

Appendix IV:

The development of the 405 from 1976 to ??

Board 12368 iss. 5/6

[This is the first board described in my service-data]

Board 12368 iss. 7 (SN > 2000 [?])

- Emitters of Tr3 and Tr4 jointly connected to C11; C9, R19 omitted and R23: $3\text{k}\Omega \rightarrow 1\text{k}\Omega$
- Subsonic-filter slightly modified (R4/R5: $10\text{k}/10\text{k} \rightarrow 22\text{k}/4\text{k}\Omega$)

Board 12368 iss. 9 (SN > 9000)

- Clamp-circuit (= DC-speaker-protection) introduced (on separate PCB at the speaker-terminals)
- C19 (1nF) added between base and collector of Tr10, and R41/L3 ($22\text{R}/6.9\mu\text{H}$) added at collector of Tr9 (to reduce dumper-speed)
- C15/C16 (100nF) added for supply-decoupling on board

Board 12368 iss. 10 (SN > 29000)

(No board-layout-change, only change of 6 component's values)

- OP-supply-voltage increased from 12V to 15V (D1/D2)
- Slope of current-limiters slightly decreased to allow for $\sim 100\text{W}$ output with $4\ \Omega$ -loads (R35/36 $0.08\text{R} \rightarrow 0.091\text{R}$ and R27/29 $8\text{k}\Omega \rightarrow 15\text{k}$)

Board 12565 iss. 3 (major revision, SN > 59000)

- R14: $560\text{R} \rightarrow 470\text{R}$ (so current [Tr1] is reduced from 6mA to 4mA -- why?)
- C11: $330\text{p} \rightarrow 1000\text{p}$
- C8: connected to opposite end of R17/C7
- R7, C5, R14; R15, R18 and R22: from emitter of Tr5 to emitter of Tr7
- C19 (see SN 9000): omitted

- R41/L3(see SN 9000): omitted
- R37/L1 (22R/6.9uH between R36 and collector of Tr10): replaced by R37/L4 (15R/22uH between R36 and emitter of Tr8)
- D10/D11 (reverse-voltage protection) 1N4003 added
- Main board incorporates clamp-circuit now
- Voltage-limiting-circuitry (only for use with old QUAD-ELS57) modified

-- 405-2 --

Board 12565 iss. 4/5 (SN > 62500)

(First 405-2 board -- fitted already in some 405-1. Nameplate change to 405-2 at SN 65000)

- New protection-circuit introduced (semi-integrated-chips replace Tr5/6 and paraphernalia; R35/36 change from .091R to 0.18R)
- Base of Tr9 connected to opposite end of D6

Board 12565 iss. 6 (SN 66700)

- D13 added between D5 and D6 (base of Tr9 connected to D6/D13-joint)
- R44 (75R) added across L2
- C20 (4.7nF) added across D2

Board 12565 iss. 7 (SN > 72500)

- Tr3 and R18 omitted, Tr4 renamed "TR3" and changed to BC556B which gives all the current gain now. -- I actually don't understand why they did that, since (at least up to the 707) this was not applied to the 606-design, where they did a different (and, at least for me, more obvious) modification of the driver-stage (see C1 above).

-- Here my service-data end --

Appendix V:

Replacement-parts

Most of the 1975-semiconductors are not available anymore. Fortunately all of them were standard parts and hence suitable – often improved -- replacements are easily available (hence there is absolutely no use in looking for the “original” ZTX-devices):

BC214C	(PNP, >30V, hfe>250, low noise)	BC559C / BC560C / BC415C
ZTX304	(NPN, >70V, ~150Mhz, hfe>50)	MPSA06 / 2N5551
ZTX504	(PNP, >70V, ~150Mhz, hfe>50)	MPSA56 / 2N5401 / [MPSA92]
40872	(Driver PNP, >100V, ~3MHz)	BD244C / [TIP42C]
17556	(Power NPN, 150V, 15A)	MJ15003 / [MJ21194]
IS920	(fast-switching diode)	1N4148 (D3, D4; speed matters!) 1N4003 (elsewhere)

B. Musquere (France) gave the following information:

TIC226B	(triac 8A / 600V)	BTA08/600B
2N4992	(silicon bilateral switch)	MBS4992, KU503A, or: Diac PDA60

A. Prodanovic (Yugoslavia) the following:

2N4992	BS 08A
SC141B	BS7-02A, MAC 216-4,

T 2801B, TW 7N400

Appendix VI: Circuit-diagram

